

AUTOMOTIVE CURRENT TRANSDUCER

HAB 80-S



Introduction

The HAB Family is best suited for DC, AC or pulsed-current measurements in high-power and low-voltage automotive applications. It contains galvanic isolation between the primary circuit (high power) and the secondary circuit (electronic circuit).

The HAB family gives you a choice of having different current measuring ranges in the same housing (from ± 20 A up to ± 100 A).

Features

- Open Loop transducer using the Hall effect sensor
- Low voltage application
- Unipolar + 5 V DC power supply
- Primary current measuring range ± 80 A
- Maximum RMS primary current limited by the busbar, the magnetic core or the ASIC temperature $T^\circ < + 150^\circ\text{C}$
- Operating temperature range: $- 40^\circ\text{C} < T^\circ < + 125^\circ\text{C}$.

Advantages

- Good accuracy for high and low current range
- Good linearity
- Low thermal offset drift
- Low thermal gain drift
- Hermetic package.

Automotive applications

- Battery Pack Monitoring
- Hybrid Vehicles
- EV and Utility Vehicles.

Principle of HAB xxx-S Family

The transducer uses open loop Hall effect technology. It provides a **Pulse Width Modulated** output Signal proportional to the magnetic Induction B generated by the primary current I_p to be measured.

The **PWM** principle is described as follow:

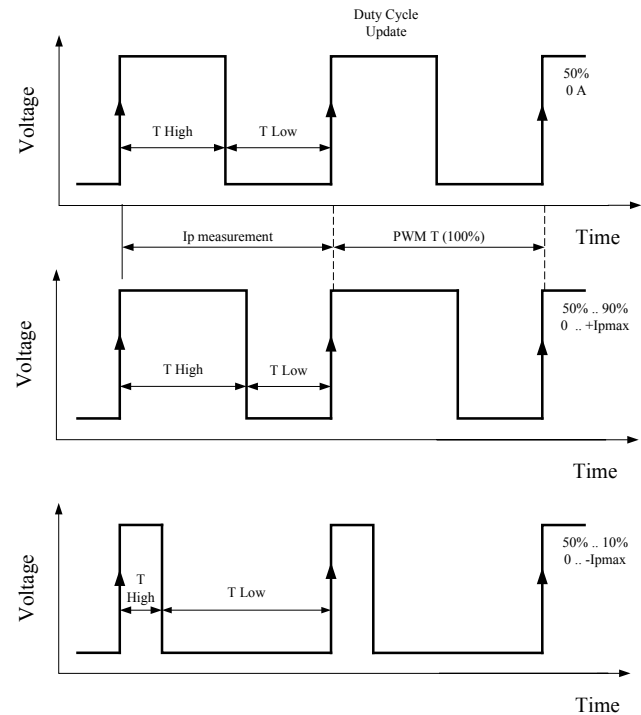

$$PWM \text{ period } T_{Period} = T_{High} + T_{Low}$$

$$PWM \text{ frequency} = \frac{1}{T_{Period}} = 125 \text{ Hz}$$

$$DutyCycle(\%) = \frac{T_{High}}{T_{Period}} \times 100$$

$$DutyCycle(\%) = 50\% + G \times I_p \text{ with } G = \text{Sensitivity } (\%/A)$$

The **PWM** period T_{period} starts on the falling edge of the output signal. The output signal of the duty cycle given during the T_{period} is the image of the primary current during the $T_{period} - 1$ period.

HAB 80-S

Dimensions HAB 80-S family (in mm)

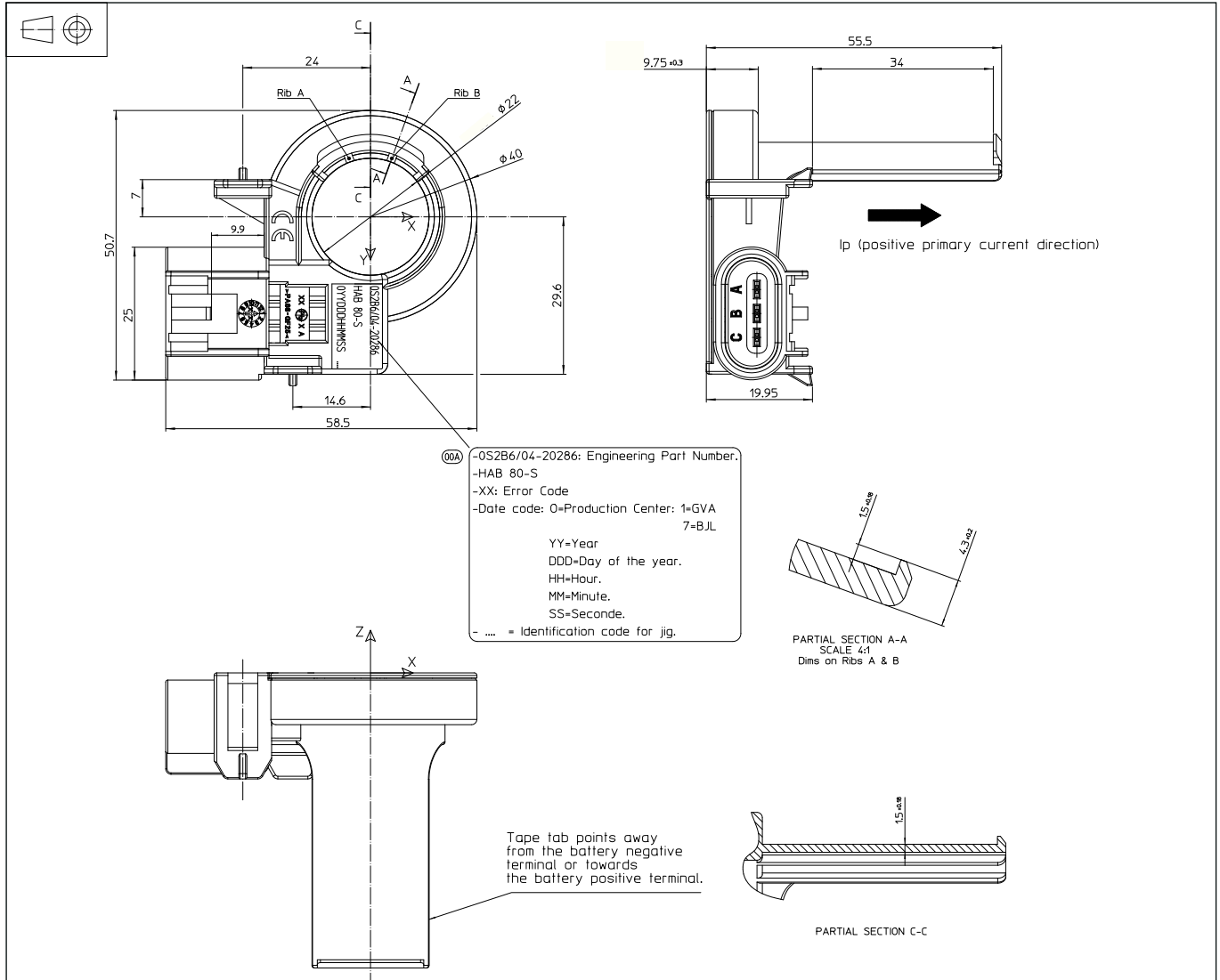

Bill of materials

- Plastic case PA 66-GF25
- Pins Brass tin plated
- *m* 25 g

System architecture

Components list	
IC1	Hall sensor ASIC
C1	100nF- $\pm 10\%$ -X7R
C2	10nF- $\pm 10\%$ -X7R
R1	51 ohms $\pm 5\%$
Z1	Bi-directional zener $\pm 12V$

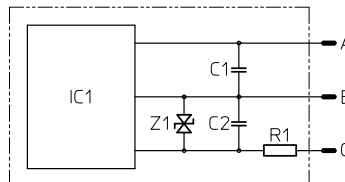

Pin out	
A	DC supply voltage (5V)
B	Ground
C	PWM output signal

Ip (A)	PWM output signal (%)
+ 80	90
0	50
- 80	10

The optional components are needed if current sensor is outside the control module circuit.

HAB 80-S

Absolute maximum ratings (not operating)

PARAMETER	Symbol	Min	Max	Unit
Maximum primary current	I_P		Infinite	A
Supply voltage	V_C	- 8.5	8.5	V
Supply voltage (over voltage $t < 1$ min)		- 14	14	V
Current consumption ($t < 1$ min)	I_C		50	mA
Output voltage ($t < 1$ min)	V_{out}	- 5	14	V
Output voltage over supply voltage	$V_{out} - V_C$		2	V
Output current	I_{out}	- 10	10	mA
Output short-circuit duration	T_c		10	min
Ambiant storage temperature	T_S	- 40	125	°C

Operating conditions

PARAMETER	Symbol	Min	Typical	Max	Unit
Supply voltage	V_C	4.5	5.00	5.5	V
Supply voltage (accurate range)	V_C	4.75	5.00	5.25	V
Pull up load resistor	R_L	2.2	4.7		K Ω
Capacitive loading	C_L			1	nF
Ambient operation temperature	T_A	- 40	25	125	°C
Ambient operation temperature (accurate range)	T_A	- 10	25	65	°C

Operating characteristics

PARAMETER	Symbol	Min	Typical	Max	Unit
Primary current nominal range	I_{PN}	-80		80	A
Maximum current measuring range (clamping)	I_{PM}	-90		90	A
Calibration current	I_{CAL}	-60		60	A
Current consumption	I_C	-	7.5	10	mA
Output PWM frequency	f_{PWM}	105	125	145	Hz
Output duty cycle sensitivity	G		0.5		%/A
Output duty cycle @ $I_p = 0$	D_{OUT}		50		%
Output duty clamping low		4	5	6	%
Output duty clamping high		94	95	96	%
Duty cycle resolution			0.0125		%
Power-up time to reach valid duty cycle				25	ms
Setting time after over load				25	ms
Output voltage high (pull up = 4.7 K Ω)	V_{OUTH}	$V_C - 0.2$			V
Output voltage low (pull up = 4.7 K Ω)	V_{OUTL}			0.2	V
Output internal resistance	R_{out}		50	100	Ω
Output PWM rise time	t_{rise}			10	μ s
Output PWM fall time	t_{fall}			10	μ s

HAB 80-S

Operating temperature

PARAMETER	Symbol	Min	Typical	Max	Unit
Electric offset current @ accurate temperature range	I_{OE}	-0.2	± 0.075	0.2	A
Electric offset current @ full temperature range		-0.3	± 0.15	0.3	A
Magnetic offset current	I_{OM}		± 0.05		A
Output resolution			0.04		A
Sensitivity error @ accurate temperature range	ε_G	-2		2	%
Sensitivity error @ full temperature range		-3		3	%
Linearity error @ 25°C	ε_L	-1		1	%