

I G B T S N U B B E R C A P A C I T O R S

KPF Box Type

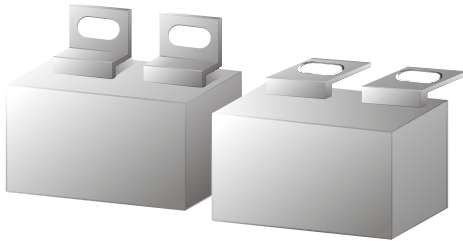

Highlights

- Self-healing property
- Low inductance
- High DV/DT
- Low ESR
- Low loss polypropylene dielectric
- Reference standard IEC 60384-14

Applications

These capacitors are used in high voltage, high current and high pulse applications such as:

- IGBT protection circuits
- Snubber networks
- Energy conversion and control in power electronics
- Protection circuits in SMPS

Construction

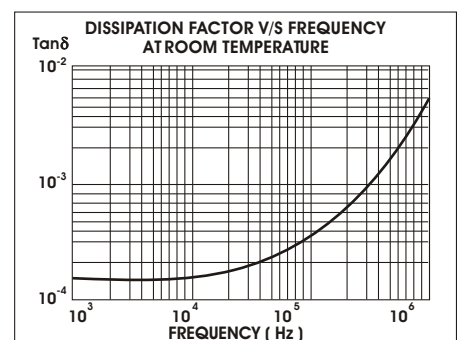
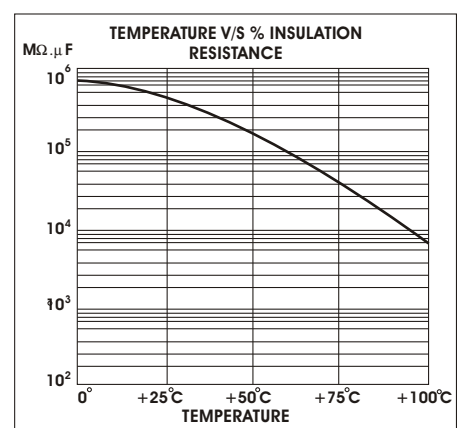
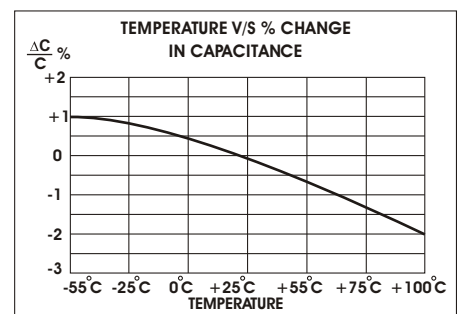
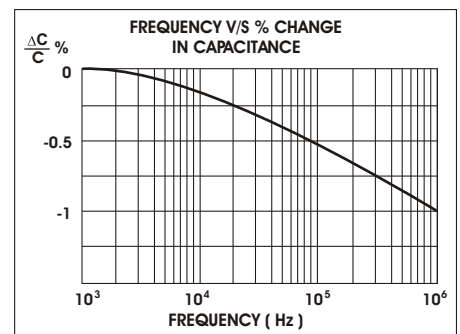
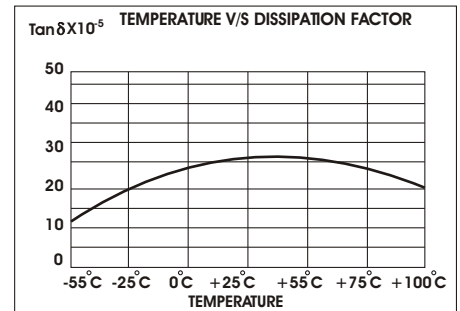
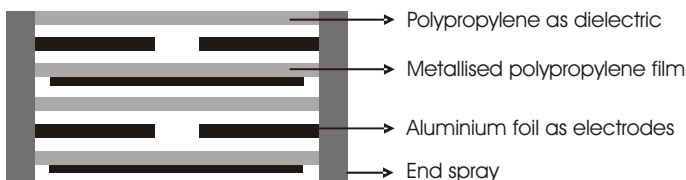

KPF Box Type

Technical Specifications

Physical Characteristics

- | | |
|--|---|
| <ul style="list-style-type: none"> • Dielectric material • Electrode material • Winding construction
 • Enclosure | <p>Polypropylene film</p> <p>Aluminium foil and metallised polypropylene film</p> <p>Polypropylene film, aluminium foil plus metallised polypropylene film wound in a series connection</p> <p>Preformed UL 94 V-0 plastic case with thermosetting resin fill</p> |
|--|---|

Electrical Characteristics

- | | | | | | | |
|---|---|--|---------------------------|------------------------|--------------------------------|-------------------------------|
| <ul style="list-style-type: none"> • Capacitance range • Capacity tolerance • Rated voltage VDC • Rated voltage VAC • Test voltage between terminals • Test voltage terminal to case • Dissipation factor (Tanδ) • Temperature range • Insulation resistance at 25°C at a test voltage of 500 VDC applied for 1 minute | <p>0.1MFD to 3.3MFD</p> <p>±5%(J), ±10%(K)</p> <p>1000, 1250, 1500, 2000</p> <p>480, 550, 630, 700</p> <p>1.6 x rated voltage VDC for 2 seconds</p> <p>3KVAC at 50Hz for 60 seconds</p> <p>≤ 0.0005 at 1 KHz and 25°C</p> <p>-40°C to +85°C</p> | <table border="0"> <tr> <td style="padding-right: 20px;">$C \leq 0.33 \text{ MFD}$</td> <td>$C > 0.33 \text{ MFD}$</td> </tr> <tr> <td style="padding-right: 20px;">$\geq 100,000 \text{ M}\Omega$</td> <td>$\geq 30,000 \text{ M}\Omega$</td> </tr> </table> | $C \leq 0.33 \text{ MFD}$ | $C > 0.33 \text{ MFD}$ | $\geq 100,000 \text{ M}\Omega$ | $\geq 30,000 \text{ M}\Omega$ |
| $C \leq 0.33 \text{ MFD}$ | $C > 0.33 \text{ MFD}$ | | | | | |
| $\geq 100,000 \text{ M}\Omega$ | $\geq 30,000 \text{ M}\Omega$ | | | | | |

Marking on Capacitors

Each capacitor will have the following information printed on it, sequentially :

- The Company's symbol  followed by the words ALCON
- The capacitor grade viz KPF
- The capacitance value MFD
- The rated voltage VDC
- Capacity tolerance and manufacturing code
- Part number on non-standard capacitors

I G B T S N U B B E R C A P A C I T O R S

KPF Box Type

Standard Capacitor Values

Working Voltage 1000 VDC (480 VAC)

Rated Capacitance MFD	Case Code	DV/DT V/ μ Sec	I Peak Amps	I _{rms} Max at 100KHz & 70°C Amps	Typical ESR at 100KHz m Ω	Terminal Styles
0.10	K2	1200	120	5.60	11.20	DL
0.15	K2	1200	180	5.70	10.80	DL
0.22	K3	1200	264	6.80	10.40	DL
0.22	B1, C1	1200	264	18.20	4.20	TL,RL,CR,CT,STL,FT,SL,MTL,TP,2P
0.27	B1, C1	1000	270	18.70	4.00	TL,RL,CR,CT,STL,FT,SL,MTL,TP,2P
0.33	B1, C1	1000	330	19.70	3.70	TL,RL,CR,CT,STL,FT,SL,MTL,TP,2P
0.39	B1, C1	1000	390	20.60	3.70	TL,RL,CR,CT,STL,FT,SL,MTL,TP,2P
0.47	B1, C1	1000	470	21.10	3.50	TL,RL,SL,STL,FT,MTL,TP,2PAB
0.56	B1	900	504	21.30	3.50	TL,RL,SL,STL,FT,MTL,TP,2P
0.68	B1	900	612	21.30	3.50	TL,RL,SL,STL,FT,MTL,TP,2P
0.75	E1	900	675	25.60	3.20	TL,RL,STL,FT,SL,MTL,TP,2P
0.82	E1	900	738	26.00	3.00	TL,RL,STL,FT,SL,MTL,TP,2P
1.00	E1	900	900	26.00	3.00	TL,RL,STL,SL,FT,MTL,TP,2P
1.20	B3	900	1080	26.00	2.50	TL,RL,STL,SL,FT,MTL,TP,3P
1.50	B3	900	1350	26.00	2.50	TL,RL,STL,SL,FT,MTL,TP,3P
1.75	E2	800	1400	28.00	2.50	TL,RL,STL,SL,FT,MTL,TP,3P
2.00	E2	800	1600	28.20	2.50	TL,RL,STL,SL,FT,MTL,TP,3P
2.20	E2	700	1540	28.50	2.40	TL,RL,STL,SL,FT,MTL,TP,3P
2.50	E3	600	1500	29.00	2.20	TL,RL,STL,SL,FT,MTL,AD,TP,4PCL
3.00	C2	600	1800	30.00	2.00	TL,RL,STL,SL,FT,MTL,AD,TP,4PCL
3.30	C2	600	1980	30.00	2.00	TL,RL,STL,SL,FT,MTL,AD,TP,4PCL

Working Voltage 1250 VDC (550 VAC)

Rated Capacitance MFD	Case Code	DV/DT V/ μ Sec	I Peak Amps	I _{rms} Max at 100KHz & 70°C Amps	Typical ESR at 100KHz m Ω	Terminal Styles
0.10	K2	1400	140	5.60	11.20	DL
0.15	K2	1400	210	5.70	10.80	DL
0.22	K3	1400	308	6.80	10.40	DL
0.22	B1, C1	1400	308	18.20	4.20	TL,RL,CR,CT,STL,FT,SL,MTL,TP,2P
0.27	B1, C1	1200	324	18.70	4.00	TL,RL,CR,CT,STL,FT,SL,MTL,TP,2P
0.33	B1, C1	1200	396	19.70	3.70	TL,RL,CR,CT,STL,FT,SL,MTL,TP,2P
0.39	B1, C1	1200	468	20.60	3.70	TL,RL,CR,CT,STL,FT,SL,MTL,TP,2P
0.47	B1	1200	564	21.10	3.50	TL,RL,SL,STL,FT,MTL,TP,2P
0.56	E1	1100	616	21.30	3.50	TL,RL,SL,STL,FT,MTL,TP,2P
0.68	E1	1100	748	21.30	3.50	TL,RL,SL,STL,FT,MTL,TP,2P
0.75	E1	1100	825	25.60	3.20	TL,RL,SL,STL,FT,MTL,TP,2P
0.82	B2	1100	902	26.00	3.00	TL,RL,SL,STL,FT,MTL,TP,2P
1.00	B2	1100	1100	26.00	3.00	TL,RL,SL,STL,FT,MTL,TP,2P
1.20	E2	800	960	26.00	2.50	TL,RL,SL,STL,FT,MTL,TP,3P
1.50	E2	800	1200	26.00	2.50	TL,RL,SL,STL,FT,MTL,TP,3P
1.75	E3	800	1400	28.00	2.50	TL,RL,STL,SL,FT,MTL,AD,CL,3P
2.00	E3	800	1600	28.20	2.50	TL,RL,STL,SL,FT,MTL,AD,CL,3P
2.20	C2	800	1760	28.50	2.40	TL,RL,STL,SL,FT,MTL,AD,CL,3P
2.50	C2	800	2000	29.00	2.20	TL,RL,STL,SL,FT,MTL,AD,CL,4P

Custom-designed capacitors are available on request

I G B T S N U B B E R C A P A C I T O R S

KPF Box Type

Standard Capacitor Values

Working voltage 1500VDC(630VAC)

Rated Capacitance MFD	Case Code	DV/DT V/ μ Sec	I Peak Amps	I _{rms} Max at 100KHz & 70°C Amps	Typical ESR at 100KHz m Ω	Terminal Styles
0.10	K2	1600	160	5.60	11.20	DL
0.15	K2	1600	240	5.70	10.80	DL
0.22	B1,C1	1600	352	18.20	4.20	TL,RL,CR,CT,STL,FT,SL,MTL,TP,2P
0.27	B1,C1	1400	378	18.70	4.00	TL,RL,CR,CT,STL,FT,SL,MTL,TP,2P
0.33	B1,C1	1400	462	19.70	3.70	TL,RL,CR,CT,STL,FT,SL,MTL,TP,2P
0.39	E1	1400	546	20.60	3.70	TL,RL,STL,FT,SL,MTL,TP,2P
0.47	E1	1400	658	21.10	3.50	TL,RL,SL,STL,FT,MTL,TP,2P
0.56	E2	1300	728	21.30	3.50	TL,RL,SL,STL,FT,MTL,TP,2P
0.68	E2	1300	884	21.30	3.50	TL,RL,SL,STL,FT,MTL,TP,2P
0.75	E2	1300	975	25.60	3.20	TL,RL,SL,STL,FT,MTL,TP,2P
0.82	E2	1300	1066	26.00	3.00	TL,RL,SL,STL,FT,MTL,TP,2P
1.00	E2	1300	1300	26.00	3.00	TL,RL,SL,STL,FT,MTL,TP,2P
1.20	E2	1300	1560	26.00	2.50	TL,RL,SL,STL,FT,MTL,TP,3P
1.50	E3	1300	1950	26.00	2.50	TL,RL,SL,STL,FT,MTL,TP,AD,CL,3P
1.75	E3	1000	1750	28.00	2.50	TL,RL,SL,STL,FT,MTL,TP,AD,CL,3P
2.00	C2	1000	2000	28.20	2.50	TL,RL,SL,STL,FT,MTL,TP,AD,CL,3P

Working voltage 2000VDC(700VAC)

Rated Capacitance MFD	Case Code	DV/DT V/ μ Sec	I Peak Amps	I _{rms} Max at 100KHz & 70°C Amps	Typical ESR at 100KHz m Ω	Terminal Styles
0.10	B1	1900	190	13.20	8.40	TL,RL,SL,STL,FT,MTL,TP,2P
0.15	B1	1900	285	15.11	7.00	TL,RL,SL,STL,FT,MTL,TP,2P
0.22	E1	1900	418	19.80	4.50	TL,RL,SL,STL,FT,MTL,TP,2P
0.27	E1	1900	513	21.70	4.30	TL,RL,SL,STL,FT,MTL,TP,2P
0.33	B2	1700	561	22.20	4.10	TL,RL,SL,STL,FT,MTL,TP,2P
0.39	B3	1700	663	22.50	4.00	TL,RL,SL,STL,FT,MTL,TP,2P
0.47	B3	1700	799	22.50	4.00	TL,RL,SL,STL,FT,MTL,TP,2P
0.56	E2	1600	896	22.70	3.80	TL,RL,SL,STL,FT,TP,MTL,2P
0.68	E3	1600	1088	22.80	3.70	TL,RL,SL,STL,FT,MTL,TP,AD,CL,2P
0.75	E3	1500	1125	23.20	3.40	TL,RL,SL,STL,FT,MTL,TP,AD,CL,2P
0.82	C2	1500	1230	23.20	3.30	TL,RL,SL,STL,FT,MTL,TP,AD,CL,2P
1.00	C2	1500	1500	23.30	3.20	TL,RL,SL,STL,FT,MTL,TP,AD,CL,2P

Custom-designed capacitors are available on request

KPF Box Type

Frequency Derating

AC Voltage Derating v/s Frequency at 10°C Internal Temperature Rise (general reference)

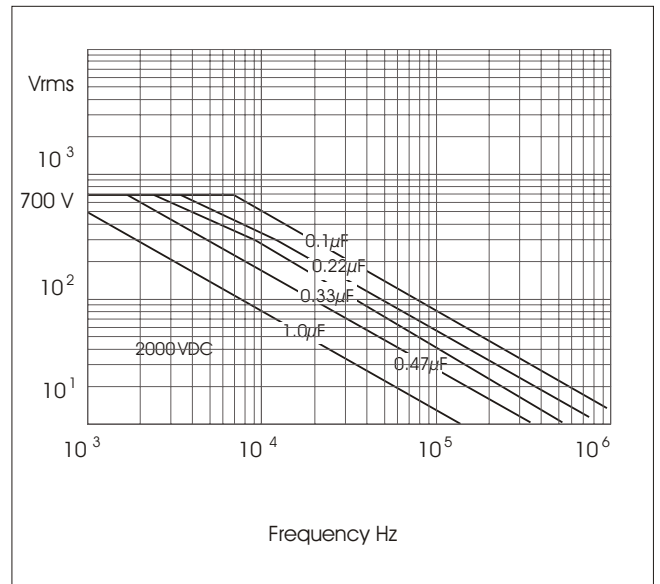
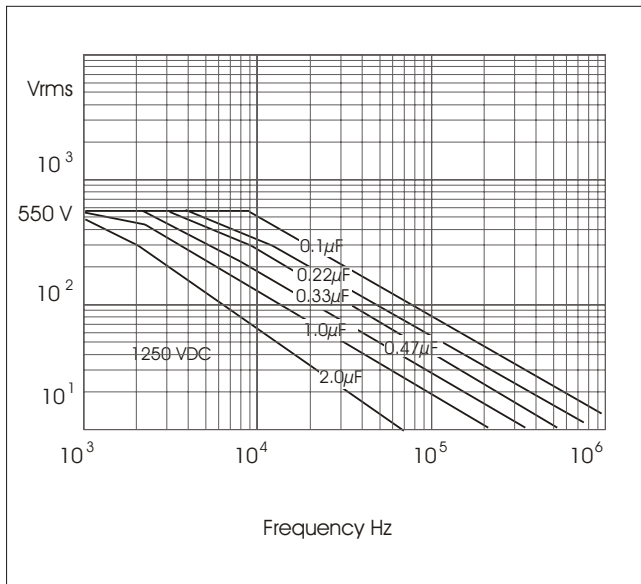
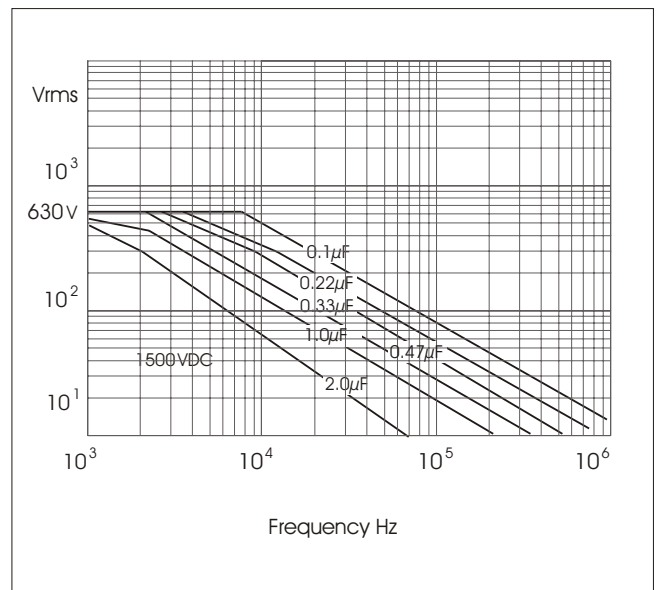
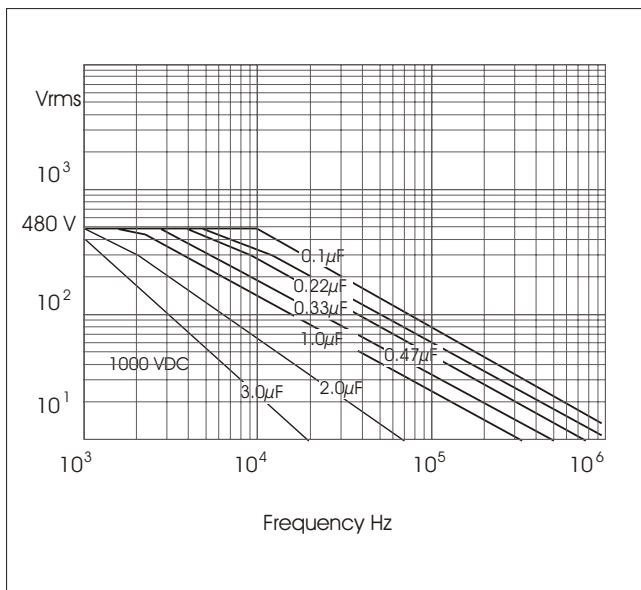

KPF Box Type

Capacitor Drawings and Terminal Styles

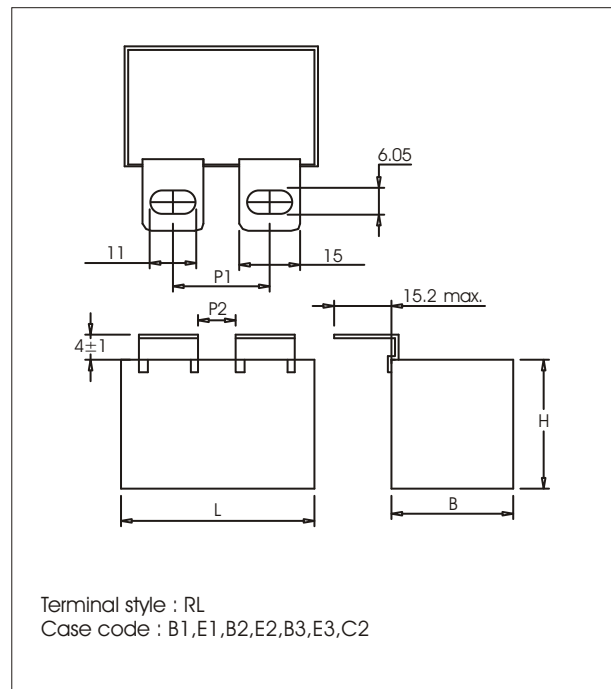
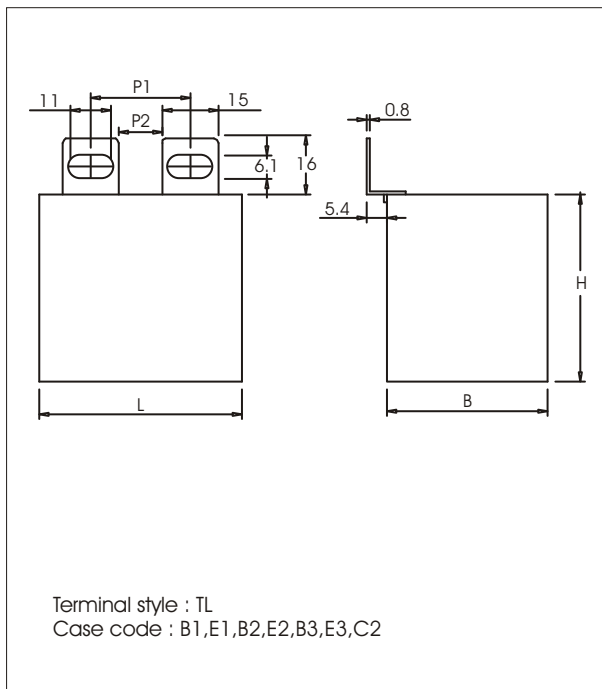
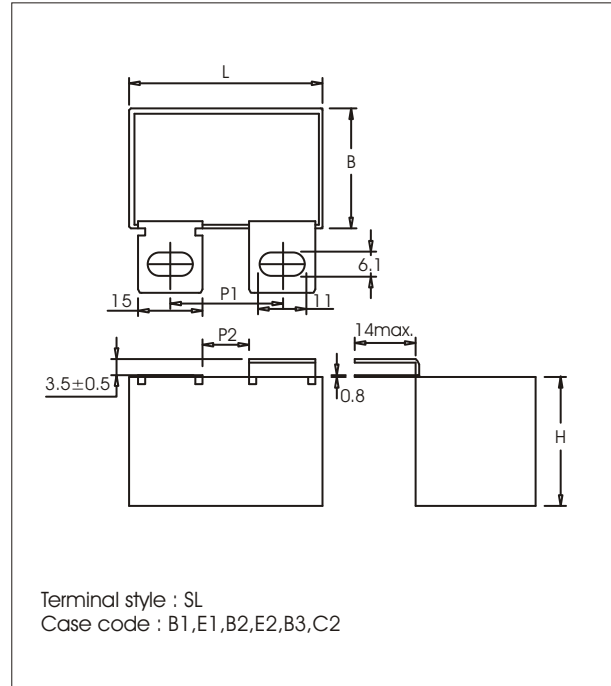
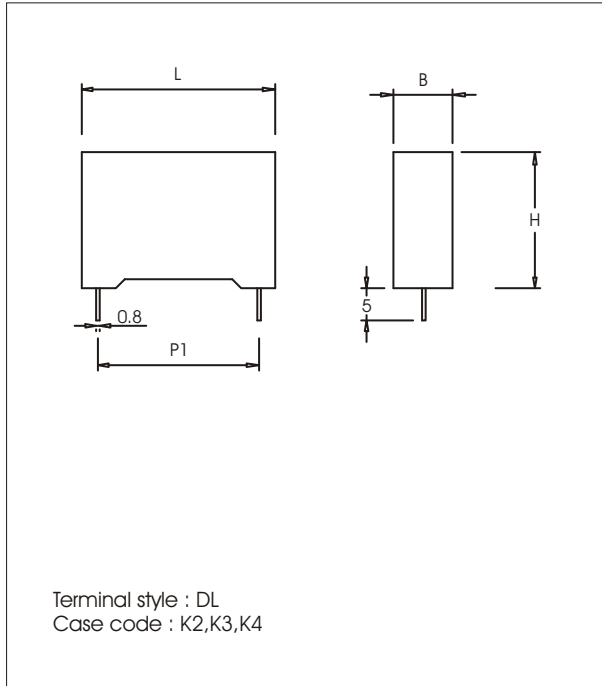

Dimensions in mm. For details see Case Code table

KPF Box Type

Capacitor Drawings and Terminal Styles

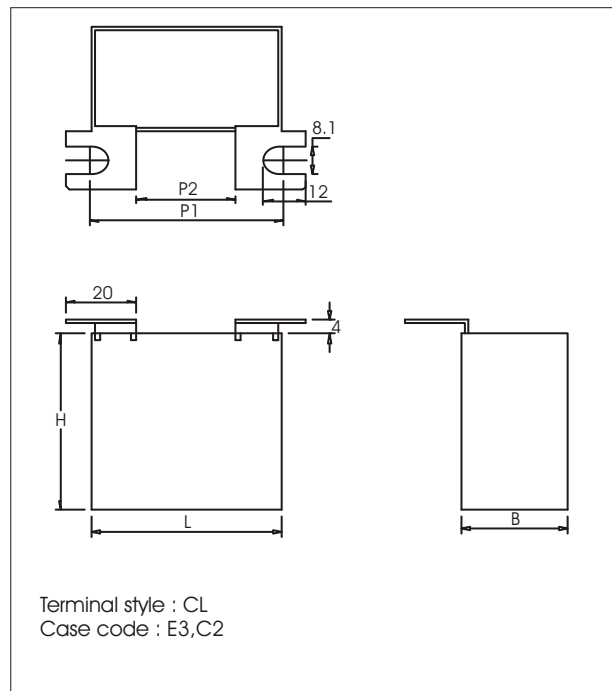
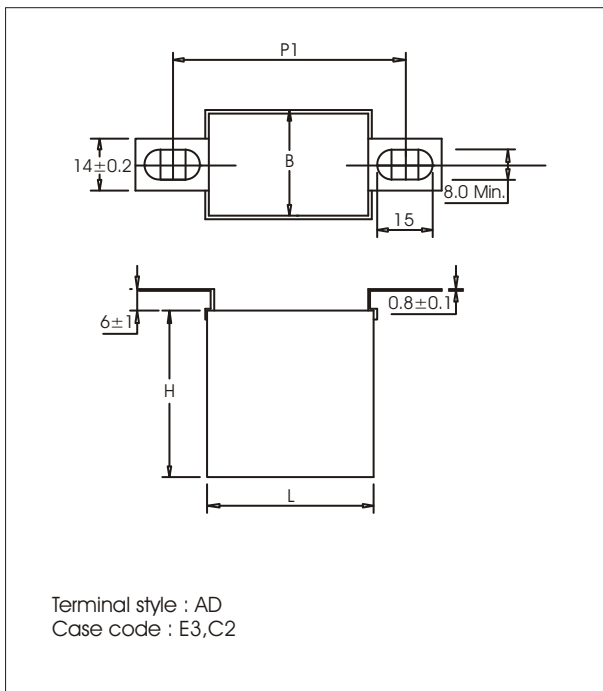
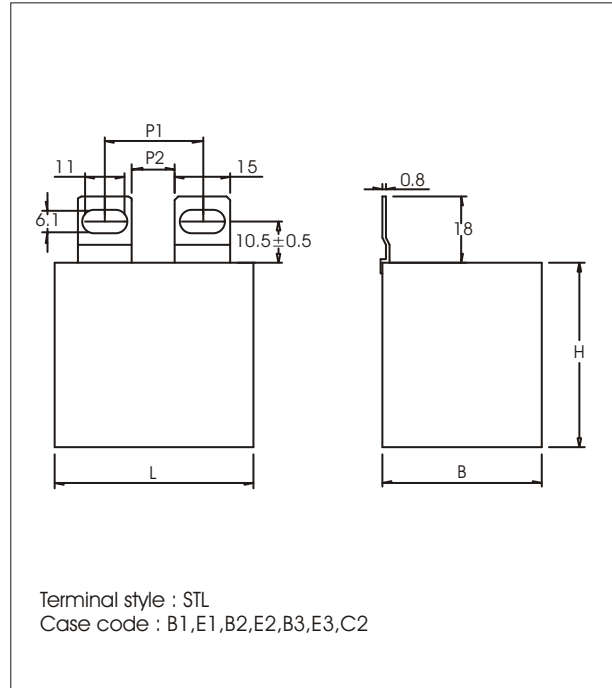
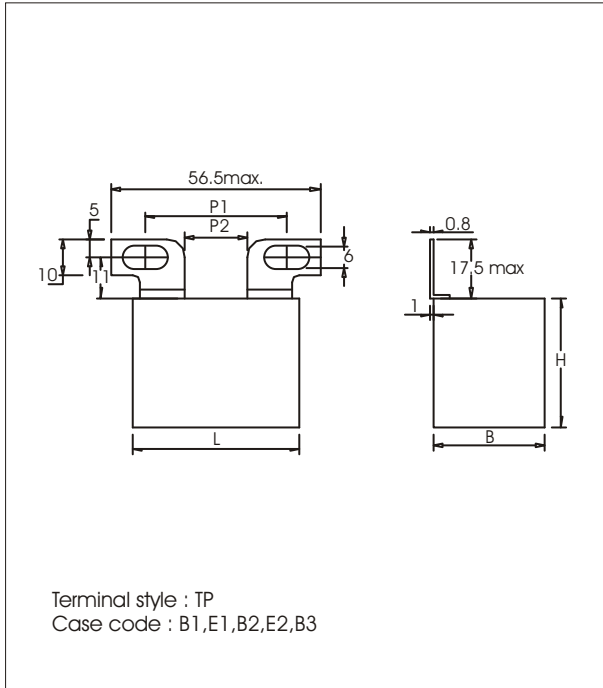

Dimensions in mm. For details see Case Code table

I G B T S N U B B E R C A P A C I T O R S

KPF Box Type

Capacitor Drawings and Terminal Styles

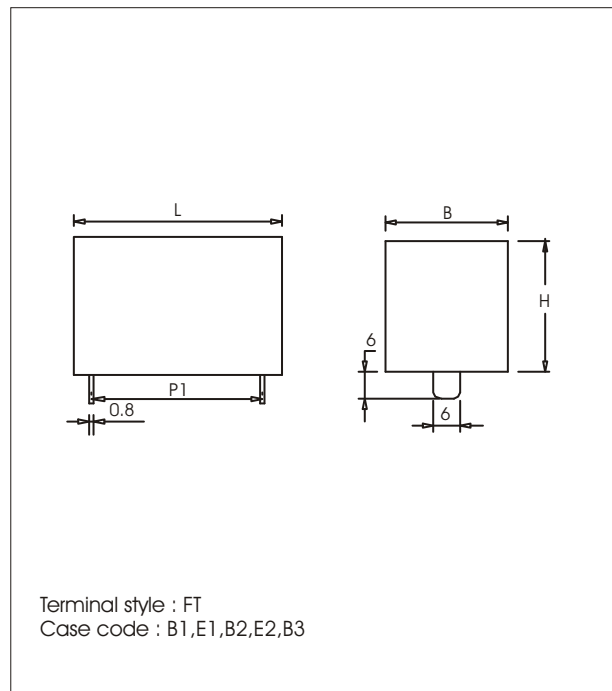
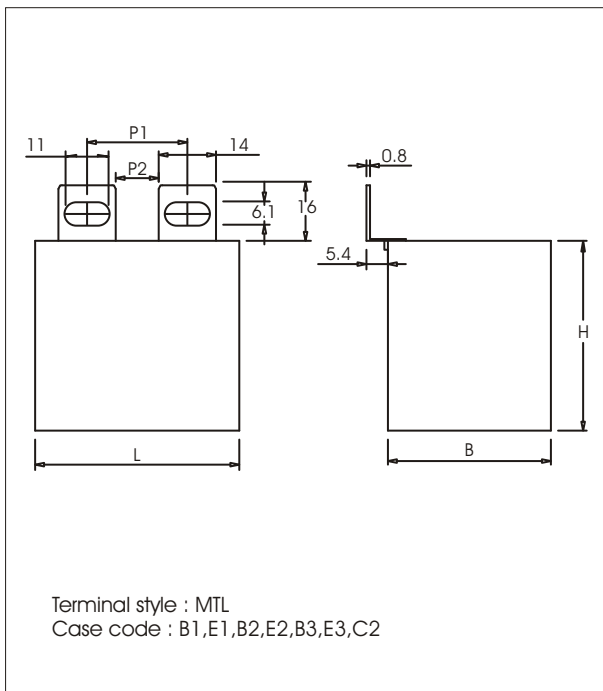
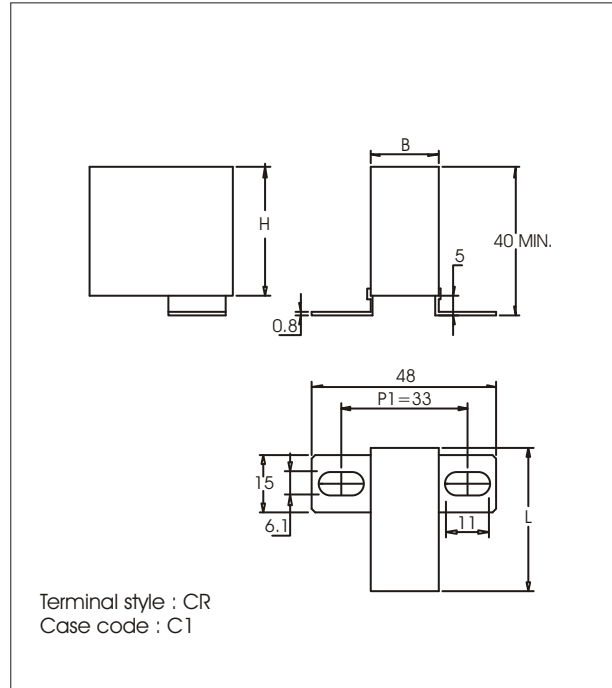
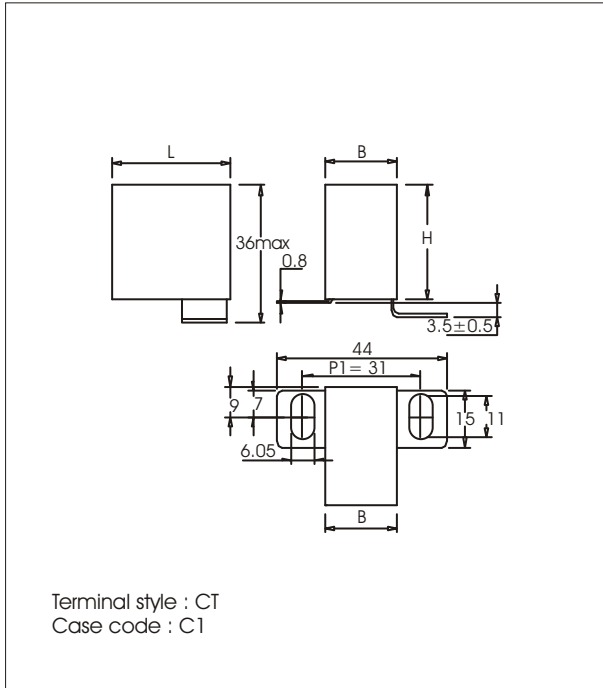

Dimensions in mm. For details see Case Code table

KPF Box Type

Capacitor Drawings and Terminal Styles

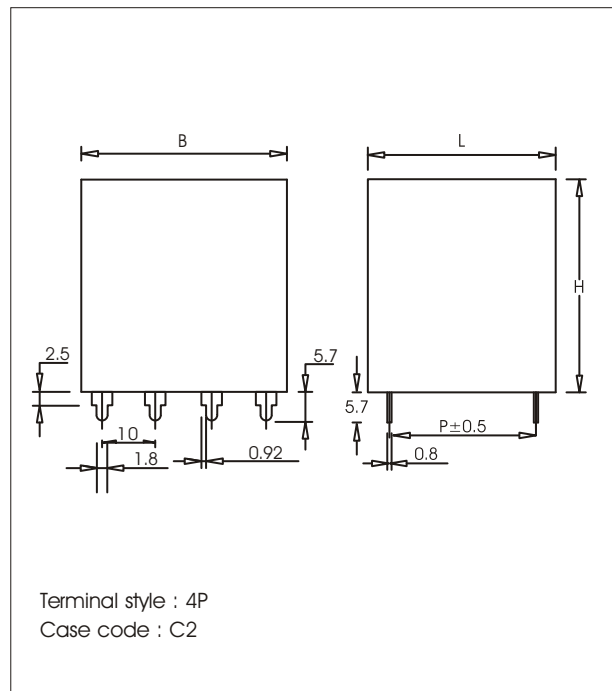
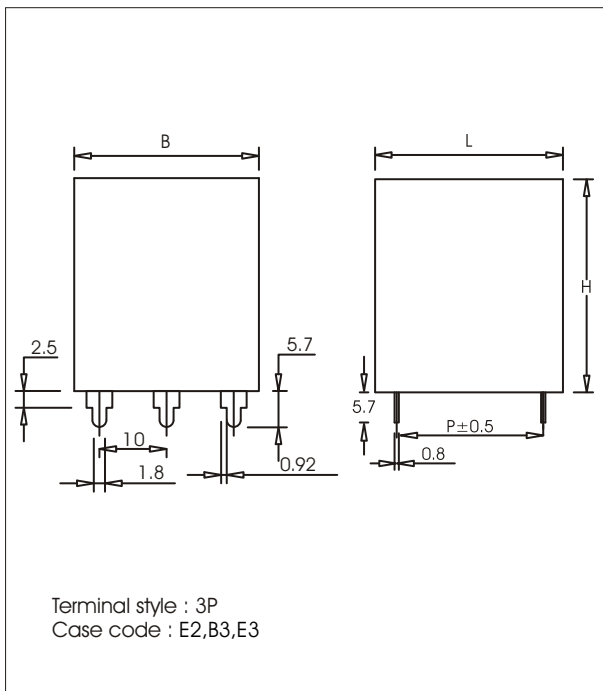
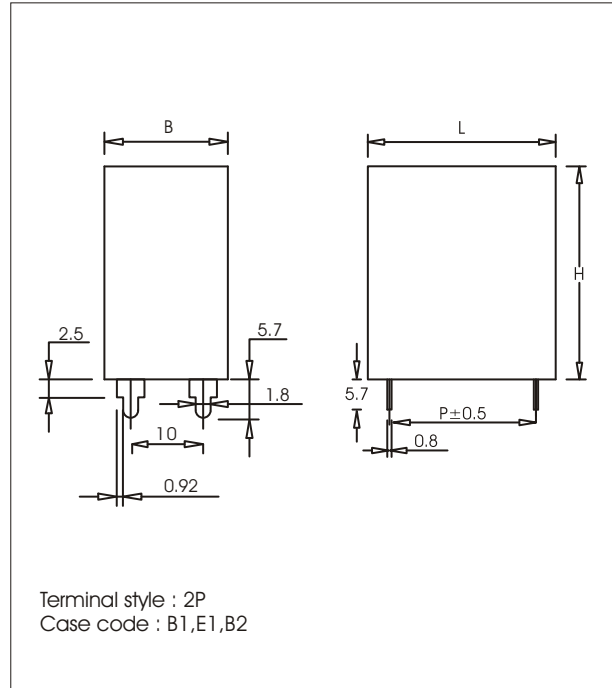
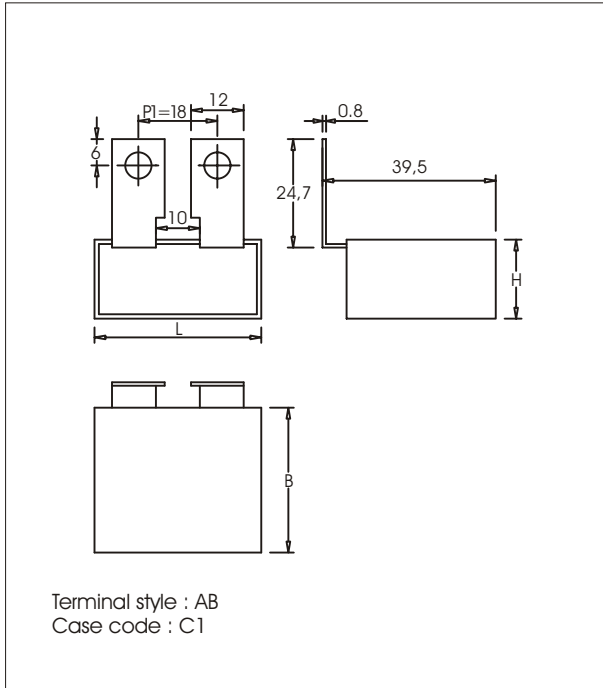

Dimensions in mm. For details see Case Code table

I G B T S N U B B E R C A P A C I T O R S

KPF Box Type

Table of Case Codes and Dimensions

Case code	Dimensions in mm*			P1	P2	Terminal Styles
	B	H	L			
K2	11.0	20.0	32.0	27.5	-	DL
K3	13.0	22.0	32.0	27.5	-	DL
K4	14.0	24.0	32.0	27.5	-	DL
B1	17.0	29.0	41.5	37.5	-	FT,2P
B1	17.0	29.0	41.5	25.5	8.5	TL,RL,STL,SL
B1	17.0	29.0	41.5	38.5	17.0	TP
B1	17.0	29.0	41.5	25.5	10.5	MTL
E1	20.0	36.0	42.0	37.5	-	FT,2P
E1	20.0	36.0	42.0	25.5	8.5	TL,RL,STL,SL
E1	20.0	36.0	42.0	38.5	17.0	TP
E1	20.0	36.0	42.0	25.5	10.5	MTL
B2	24.0	38.0	45.0	37.5	-	FT,2P
B2	24.0	38.0	45.0	25.5	8.5	TL,RL,STL,SL
B2	24.0	38.0	45.0	38.5	17.0	TP
B2	24.0	38.0	45.0	25.5	10.5	MTL
E2	35.0	42.0	45.0	37.5	-	FT,3P
E2	35.0	42.0	45.0	27.0	11.5	TL,RL,STL,SL
E2	35.0	42.0	45.0	38.5	17.0	TP
E2	35.0	42.0	45.0	27.0	13.0	MTL
B3	30.0	45.0	45.0	37.5	-	FT,3P
B3	30.0	45.0	45.0	27.0	11.5	TL,RL,STL,SL
B3	30.0	45.0	45.0	38.5	17.0	TP
B3	30.0	45.0	45.0	27.0	13.0	MTL
E3	35.0	46.0	54.0	48.0	-	3P
E3	35.0	46.0	54.0	27.0	11.5	TL,RL,STL,SL
E3	35.0	46.0	54.0	27.0	13.0	MTL
E3	35.0	46.0	54.0	68.5	-	AD
E3	35.0	46.0	54.0	55.0	28.0	CL
C2	43.0	50.0	54.0	48.0	-	4P
C2	43.0	50.0	54.0	27.0	11.5	TL,RL,STL,SL
C2	43.0	50.0	54.0	27.0	13.0	MTL
C2	43.0	50.0	54.0	68.5	-	AD
C2	43.0	50.0	54.0	55.0	28.0	CL
C1	18.0	33.0	38.0	31.0	-	CT
C1	18.0	33.0	38.0	18.0	-	AB
C1	18.0	33.0	38.0	33.0	-	CR

* Refer to "Capacitor Drawings"

Precaution

1. These capacitors are not suitable for 'across the line' applications
2. VAC (rated) : Frequency should be less than 1000Hz
3. VDC (rated) : $1.4 \times V_{rms} + VDC$ should be less than rated VDC